

HD10AMA HD/SD 4-Channel Analog Embedder/Disembedder User Manual

HD10AMA



AJA
AJA VIDEO SYSTEMS INC

May 16, 2005 P/N 101659-00

Trademarks

AJA, Io, and Kona are trademarks of AJA Video, Inc. All other trademarks are the property of their respective holders.

Notice

Copyright © 2005 AJA Video, Inc. All rights reserved. All information in this manual is subject to change without notice. No part of the document may be reproduced or transmitted in any form, or by any means, electronic or mechanical, including photocopying or recording, without the express written permission of AJA Inc.

FCC Emission Information

This equipment has been tested and found to comply with the limits for a Class A digital device, pursuant to Part 15 of the FCC Rules. These limits are designed to provide reasonable protection against harmful interference when the equipment is operated in a commercial environment. This equipment generates, uses and can radiate radio frequency energy and, if not installed and used in accordance with the instruction manual, may cause harmful interference to radio communications. Operation of this equipment in a residential area is likely to cause harmful interference in which case the user will be required to correct the interference at his own expense. Changes or modifications not expressly approved by AJA Video can effect emission compliance and could void the user's authority to operate this equipment.

Contacting Support

To contact AJA Video for sales or support, use any of the following methods:

443 Crown Point Circle, Grass Valley, CA. 95945 USA

Telephone: +1.800.251.4224 or +1.530.274.2048

Fax: +1.530.274.9442

Web: <http://www.aja.com>

Support Email: support@aja.com

Sales Email: sales@aja.com

When calling for support, have all information on the product (serial number etc.) at hand prior to calling.

Introduction

The HD10AMA is a dual rate 4 channel analog audio Embedder/Disembedder. The Disembedder is always functional providing 4 outputs. The Embedder is user selectable, on a channel pair basis, to either “pass” input audio or embed input audio from the breakout cable. Analog audio levels are selectable. The HD10AMA automatically detects and configures to the input video standard.

Features

- Dual rate HD-SDI/SDI Embedder/Disembedder
- 4 Channel Balanced Analog Audio I/O
- Supplied XLR breakout cable
- HD-SDI/SDI input, 2 HD-SDI/SDI outputs
- Dipswitch configuration
- 5-18VDC Power

Block Diagram

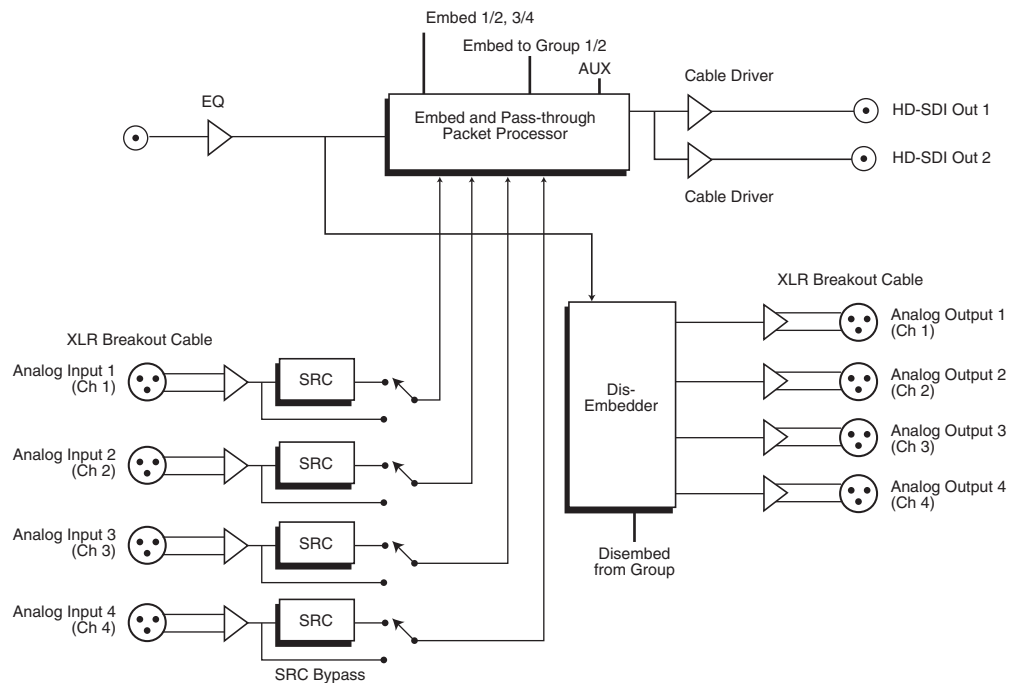

HD10AMA, Block Diagram

I/O Connections

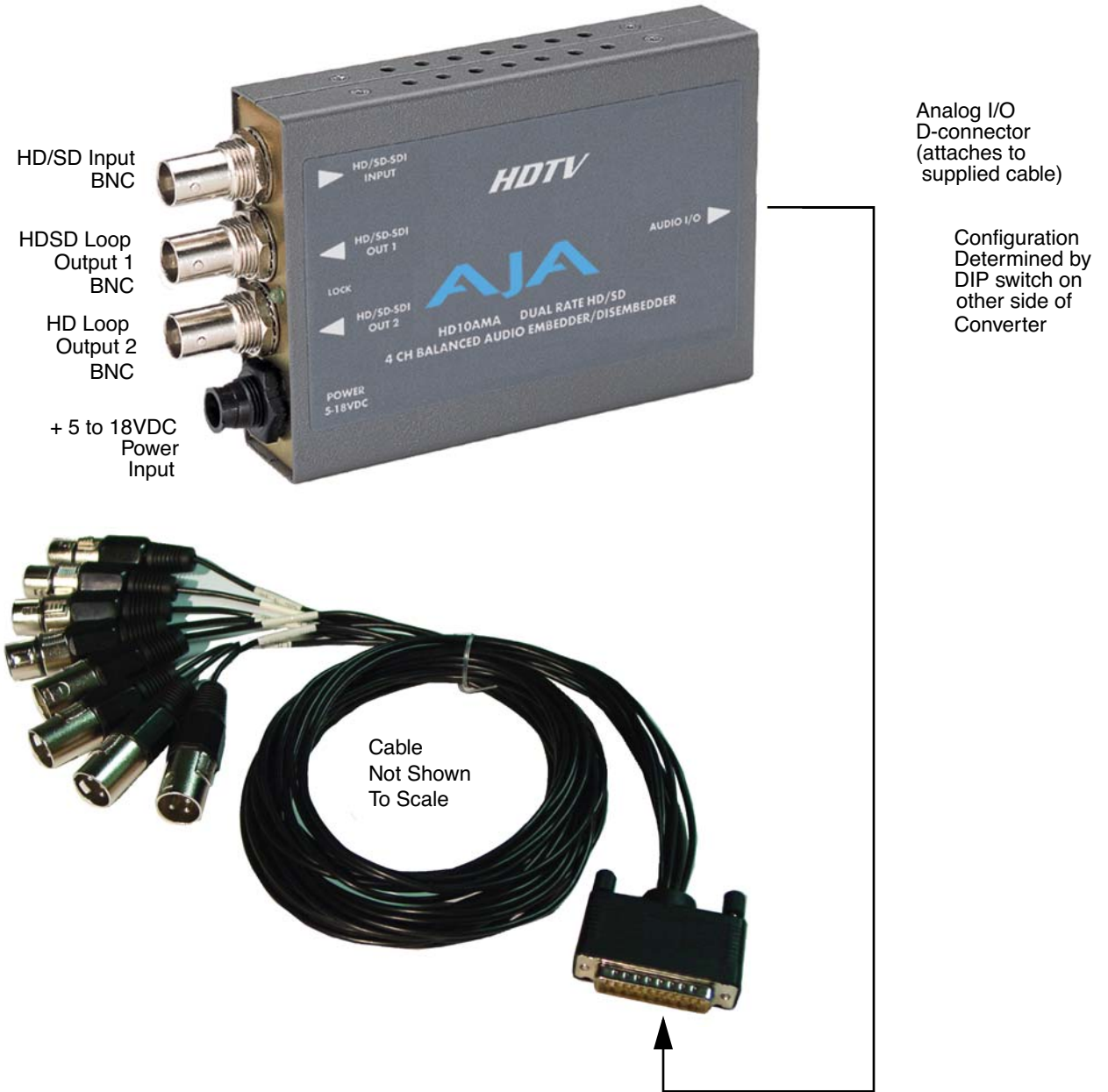

HD10AMA and Cable, Side View

User Controls

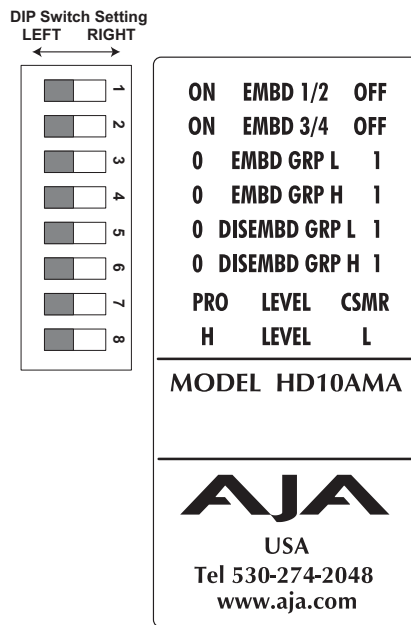

The user interface for the HD10AMA is an 8-switch DIP accessible through a cut-out in the bottom of the unit. Use the DIP switches to configure how the Analog embedding and disembedding functions.

Note: The combination of the AUX switch setting (switch 8) and the other switches determines the overall operation of the HD10AMA.

The exact function of each DIP switch and what it controls is described on the following pages.

Switch 1 (EMBD 1/2)—Controls Audio Embedding for Channels 1/2

LEFT	RIGHT
Overwrite or embed new channel 1/2 packets	If AUX=LEFT: Pass any channel 1/2 packets on input SDI If AUX=RIGHT: Delete all channel 1/2 packets from input SDI

Switch 2 (EMBD 3/4)—Controls Audio Embedding for Channels 3/4

LEFT	RIGHT
Overwrite or embed new channel 3/4 packets	If AUX=LEFT: Pass any channel 3/4 packets on input SDI If AUX=RIGHT: Delete all channel 3/4 packets from input SDI

Switches 3 and 4 (EMBD GRP L) and (EMBD GRP H)—Select AES Channel Mapping For Embedded Groups

The following tables show how combinations of setting these two switches affects channel mapping.

Switch 3: EMBD GRP L Left (0), Switch 4: EMBD GRP H Left (0)

Audio Input Channel	SDI Embedded Output Group	SDI Embedded Output Channel
1 →	1	1
2 →	1	2
3 →	1	3
4 →	1	4

Switch 3: EMBD GRP L Right (1), Switch 4: EMBD GRP H Left (0)

Audio Input Channel	SDI Embedded Output Group	SDI Embedded Output Channel
1 →	2	5
2 →	2	6
3 →	2	7
4 →	2	8

Switch 3: EMBD GRP L Left (0), Switch 4: EMBD GRP H Right (1)

Audio Input Channel	SDI Embedded Output Group	SDI Embedded Output Channel
1 →	3	9
2 →	3	10
3 →	3	11
4 →	3	12

Switch 3: EMBD GRP L Right (1), Switch 4: EMBD GRP H Right (1)

Audio Input Channel	SDI Embedded Output Group	SDI Embedded Output Channel
1 →	4	13
2 →	4	14
3 →	4	15
4 →	4	16

Switches 5 and 6 (DISEMBD GRP L) and (DISEMBD GRP H)—Select AES Channel Mapping For Disembedding Groups

The following tables show how combinations of setting these two switches affects channel mapping.

Switch 5: DISEMBD GRP L Left (0), Switch 6: DISEMBD GRP H Left (0)

SDI Embedded Input Group	SDI Embedded Input Channel	Audio Output Channel
1	1 →	1
1	2 →	2
1	3 →	3
1	4 →	4

Switch 5: DISEMBD GRP L Right (1), Switch 6: DISEMBD GRP H Left (0)

Audio Input Channel	SDI Embedded Output Group	SDI Embedded Output Channel
2	5 →	1
2	6 →	2
2	7 →	3
2	8 →	4

Switch 5: DISEMBD GRP L Left (0), Switch 6: DISEMBD GRP H Right (1)

Audio Input Channel	SDI Embedded Output Group	SDI Embedded Output Channel
3	9 →	1
3	10 →	2
3	11 →	3
3	12 →	4

Switch 5: DISEMBD GRP L Right (1), Switch 6: DISEMBD GRP H Right (1)

Audio Input Channel	SDI Embedded Output Group	SDI Embedded Output Channel
4	13 →	1
4	14 →	2
4	15 →	3
4	16 →	4

Switch 7 (LEVEL)—Control Whether Audio Levels are Professional Or Consumer. Affects all 4 Inputs

LEFT	RIGHT
Professional Level. +4 dBu is typical of most professional audio (See Output Level Selection Matrix Table)	Consumer Level. -7 to -8 dBu is typical of most consumer audio (See Output Level Selection Matrix Table)

Note: Professional audio equipment has much higher levels than consumer equipment: a 0 VU reading corresponds to +4 dBu. Connecting a professional +4 dBu device to a consumer audio input (-7 to -8 dBu) may produce dangerous overloading, whereas the output of a consumer device probably does not have sufficient power to drive a professional audio input. With consumer and semi-professional audio equipment, a VU reading of 0 dB is typically referenced to -10 dBV, which itself is referenced to 0 dBV = 1 V RMS.

Switch 8 (LEVEL)—Control Whether Audio Levels are High or Low. Affects all 4 Inputs

LEFT	RIGHT
High Level (See Output Level Selection Matrix Table)	Low Level (See Output Level Selection Matrix Table)

Output Level Selection Matrix For Switches 7 and 8

The following table shows the combinations of DIP switch settings required to configure the audio output levels shown.

Output Level	DIP Switch #7	DIP Switch #8
Audio Levels (Full Scale Digital): +24dbu,	LEFT	LEFT
Audio Levels (Full Scale Digital): +18dbu	LEFT	RIGHT
Audio Levels (Full Scale Digital): +14dbu	RIGHT	RIGHT

Installation

Typically, HD10AMA installation consists of the following:

1. disconnect +5VDC from the converter
2. configure the DIP switch for the desired equipment configuration and video formats
3. connect video equipment to the converter BNCs
4. apply +5VDC power to the converter (AJA power supply model DWP)

Specifications

Item	Specification
Formats	HD SMPTE 292/296M SD SMPTE 259M (Automatic Configuration)
Video Input	HD-SDI or SDI BNC
Video Outputs	Follows input, 2 x BNC
Audio Inputs	4 x Balanced Analog Audio, XLR
Audio Outputs	4 x Balanced Analog Audio, XLR
Audio Levels (Full Scale Digital)	+24dbu, +18dbu, +14dbu
Audio Converters	24 bit
Embedded Audio	SMPTE 272M/299M, 24 bit, 48KHz synchronous
User Controls	External Dipswitch: Embedder on/off, Ch pairs 1/2 - 3/4 Input group select, 1-4 Output Group Select, 1-4 Audio Level: Pro/Consumer
Size	5.8" x 3.1" x 1 (147 x 79 x 25mm)
Power	5-18V, 5 watts. Requires power supply.

