

HD10AM HD/SD 8-Channel AES Embedder/Disembedder User Manual

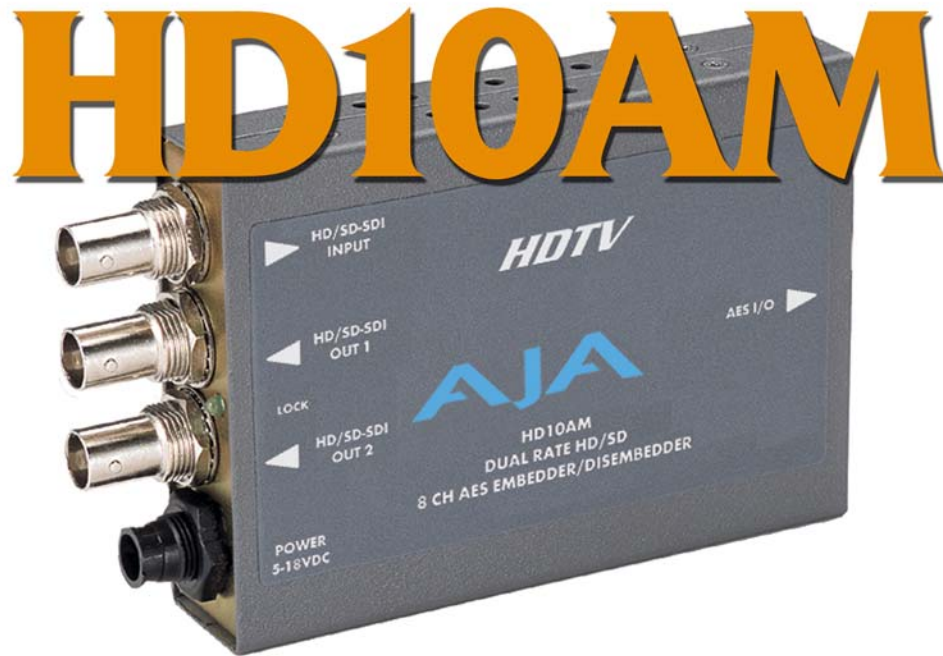

AJA
AJA VIDEO SYSTEMS INC

May 17, 2005 P/N 101660-00

Trademarks

AJA, Io, and Kona are trademarks of AJA Video, Inc. All other trademarks are the property of their respective holders.

Notice

Copyright © 2005 AJA Video, Inc. All rights reserved. All information in this manual is subject to change without notice. No part of the document may be reproduced or transmitted in any form, or by any means, electronic or mechanical, including photocopying or recording, without the express written permission of AJA Inc.

FCC Emission Information

This equipment has been tested and found to comply with the limits for a Class A digital device, pursuant to Part 15 of the FCC Rules. These limits are designed to provide reasonable protection against harmful interference when the equipment is operated in a commercial environment. This equipment generates, uses and can radiate radio frequency energy and, if not installed and used in accordance with the instruction manual, may cause harmful interference to radio communications. Operation of this equipment in a residential area is likely to cause harmful interference in which case the user will be required to correct the interference at his own expense. Changes or modifications not expressly approved by AJA Video can effect emission compliance and could void the user's authority to operate this equipment.

Contacting Support

To contact AJA Video for sales or support, use any of the following methods:

443 Crown Point Circle, Grass Valley, CA. 95945 USA

Telephone: +1.800.251.4224 or +1.530.274.2048

Fax: +1.530.274.9442

Web: <http://www.aja.com>

Support Email: support@aja.com

Sales Email: sales@aja.com

When calling for support, have all information on the product (serial number etc.) at hand prior to calling.

Introduction

The HD10AM is a dual rate 8 channel AES audio Embedder/Disembedder. The Disembedder is always functional, outputting group 1 and 2—or 3 and 4 (user selectable) when present on the input SDI. This is independent of the embedding process. The Embedder is user selectable, on a channel pair basis, to either “pass” SDI input audio or embed input AES audio from the breakout cable. The ability to pass incoming ancillary data makes it possible to embed up to 16 channels of audio by cascading two units: the first embedding to groups 1/2, and the second embedding to groups 3/4—or vice versa. It also means that any ancillary data packets in compliance with SMPTE 291M will be passed through as-is.

AES inputs are sample rate converted to a 48KHz rate synchronous to the video input. The HD10AM automatically detects and configures to the input video standard.

Features

- Dual rate HD-SDI/SDI Embedder/Disembedder
- 8 Channel AES I/O
- Supplied breakout cable for balanced AES - XLR connectors
- HD-SDI/SDI input
- 2 HD-SDI/SDI equalized outputs (following input)
- Dipswitch configuration
- 5-18VDC Power

Block Diagram

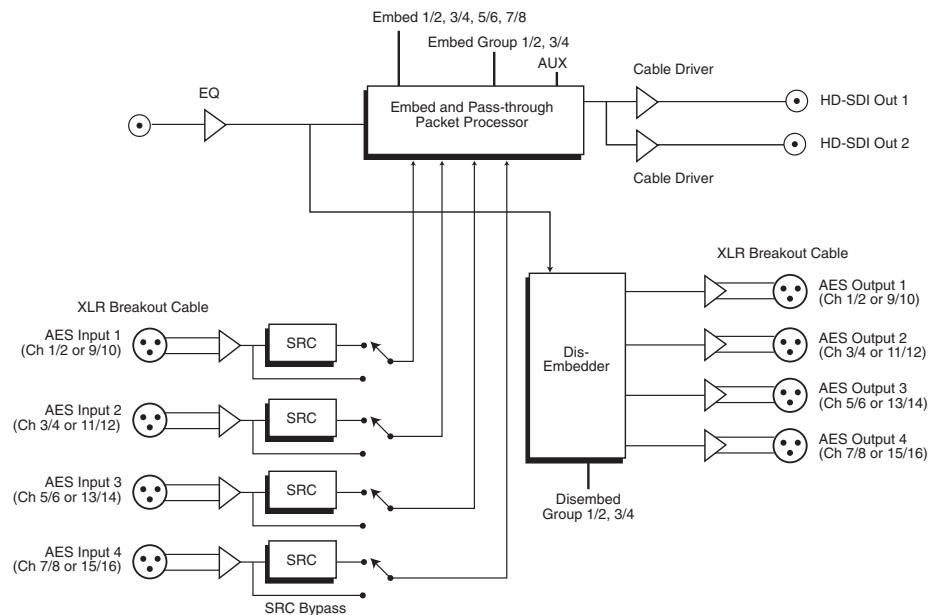

HD10AM, Block Diagram

I/O Connections

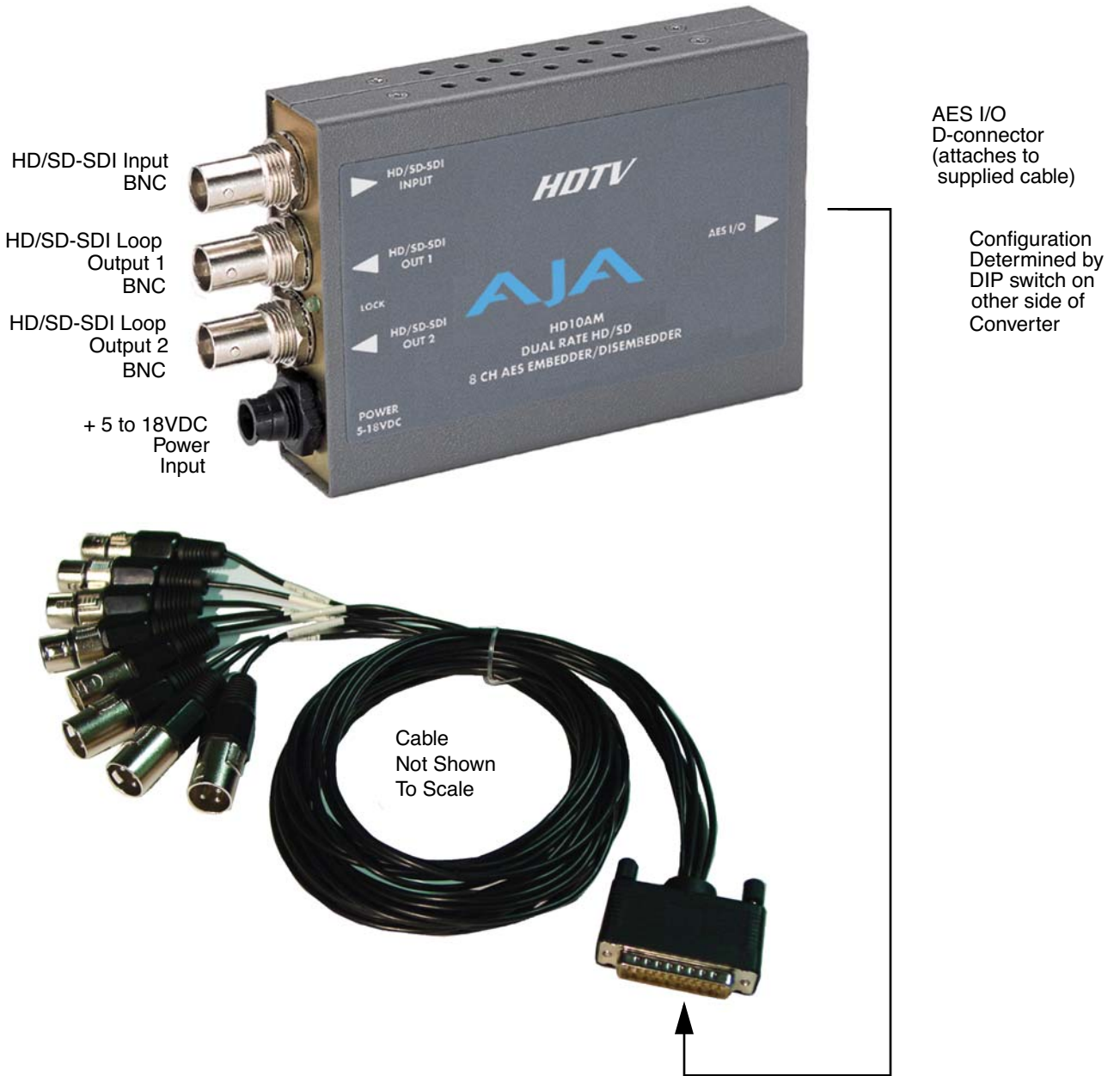

HD10AM and Cable, Side View

User Controls

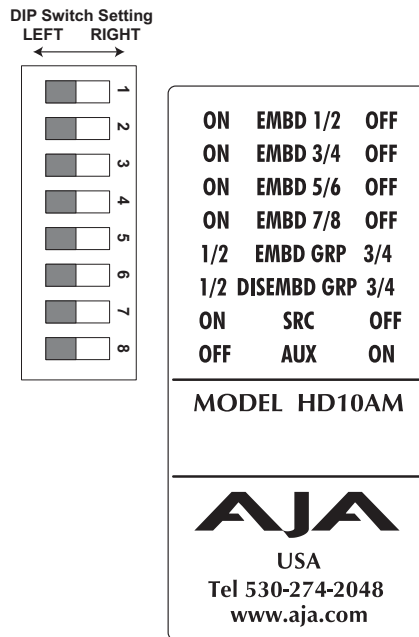

The user interface for the HD10AM is an 8-switch DIP accessible through a cut-out in the bottom of the unit. Use the DIP switches to configure how the AES embedding and disembedding functions.

Note: The combination of the AUX switch setting (switch 8) and the other switches determines the overall operation of the HD10AM.

The exact function of each DIP switch and what it controls is described on the following pages.

Factory default switch settings are all in the leftmost position.

Switch 1 (EMBD 1/2)—Controls audio embedding for channels 1/2

LEFT	RIGHT
Overwrite or embed new channel 1/2 packets	If AUX=LEFT: Pass any channel 1/2 packets on input SDI If AUX=RIGHT: Delete all channel 1/2 packets from input SDI

Switch 2 (EMBD 3/4)—Controls audio embedding for channels 3/4

LEFT	RIGHT
Overwrite or embed new channel 3/4 packets	If AUX=LEFT: Pass any channel 3/4 packets on input SDI If AUX=RIGHT: Delete all channel 3/4 packets from input SDI

Switch 3 (EMBD 5/6)—Controls audio embedding for channels 5/6

LEFT	RIGHT
Overwrite or embed new channel 5/6 packets	If AUX=LEFT: Pass any channel 5/6 packets on input SDI If AUX=RIGHT: Delete all channel 5/6 packets from input SDI

Switch 4 (EMBD 7/8)—Controls audio embedding for channels 7/8

LEFT	RIGHT
Overwrite or embed new channel 7/8 packets	If AUX=LEFT: Pass any channel 7/8 packets on input SDI If AUX=RIGHT: Delete all channel 7/8 packets from input SDI

Switch 5 (EMBD GRP)—Select AES channel mapping for embedded groups

LEFT	RIGHT
Embed to Groups 1 and 2 as specified in 272M and 299M (see following table)	Embed to Groups 3 and 4 as specified in 272M and 299M (see following table)

Switch 5 set LEFT, Embed to Groups 1 and 2, AES Channel Mapping:

AES Input Channel	SDI Embedded Group	Channel
1 →	1	1
2 →	1	2
3 →	1	3
4 →	1	4
5 →	2	5
6 →	2	6
7 →	2	7
8 →	2	8

Switch 5 set RIGHT, Embed to Groups 3 and 4, AES Channel Mapping:

AES Input Channel	SDI Embedded Group	Channel
1 →	3	9
2 →	3	10
3 →	3	11
4 →	3	12
5 →	4	13
6 →	4	14
7 →	4	15
8 →	4	16

Switch 6 (DISEMBD GRP)—Select AES channel mapping for disembedding groups

LEFT	RIGHT
Disembled from Groups 1 and 2 as specified in 272M and 299M (see following table)	Disembled from Groups 3 and 4 as specified in 272M and 299M (see following table)

Switch 6 set LEFT, disembled from Groups 1 and 2, AES Channel Mapping:

SDI Embedded Input Group	Channel	AES Output Channel
1 1	1 → 2 →	1 2
1 1	3 → 4 →	3 4
2 2	5 → 6 →	5 6
2 2	7 → 8 →	7 8

Switch 6 set RIGHT, disembled from Groups 3 and 4, AES Channel Mapping:

SDI Embedded Input Group	Channel	AES Output Channel
3 3	9 → 10 →	1 2
3 3	11 → 12 →	3 4
4 4	13 → 14 →	5 6
4 4	15 → 16 →	7 8

Switch 7 (SRC)—Control whether input AES audio is passed through the sample rate converters

LEFT	RIGHT
Pass all input AES audio through the sample rate converter before embedding	Do not pass any input AES audio through the sample rate converter before embedding

Note: Switch 7 affects all four inputs. When non-audio AES packets are detected at the inputs, each individual SRC will be automatically bypassed for that channel. For proper operation with the SRC bypassed, the AES input timing must be externally synchronized to the input SDI.

Switch 8 (AUX)—Control whether ancillary horizontal data is passed or deleted from input (used with switches 1 through 4)

LEFT	RIGHT
Whenever possible, pass all incoming ancillary data except packets marked for deletion	Delete all incoming horizontal ancillary data before embedding any new audio packets

Installation

Typically, HD10AM installation consists of the following:

1. disconnect +5VDC from the converter
2. configure the DIP switch for the desired equipment configuration
3. connect video equipment to the converter BNCs
4. apply +5VDC power to the converter (AJA power supply model DWP)

Specifications

Item	Specification
Formats	HD SMPTE 292/296/274M SD SMPTE 259M (Automatic Configuration)
Video Input	HD-SDI or SDI BNC
Video Outputs (equalized)	HD-SDI or SDI BNC, 2 x BNC
Audio Inputs	4 x AES3 110 ohm XLR, Pro format
Audio Outputs	4 x AES3 110 ohm XLR, Pro format
Embedded Audio	SMPTE 272M (SD): 20-bit SMPTE 299M (HD): 24 bit, 48KHz synchronous
Processing Delay (matched for A/V)	7 μ S for HD Mode 19 μ S for SD Mode
Sample Rate Converter Resolution	24-bits
User Controls	External Dipswitch: Embedder on/off, Ch pairs 1/2 - 7/8 Input group select, 1/2, 3/4 Output Group Select, 1/2, 3/4 SRC Bypass AUX (pass or delete incoming ancillary data)
Size	5.8" x 3.1" x 1 (147 x 79 x 25mm)
Power	5-18V, 5 watts. Requires power supply.